

CSP-M COMPRESSION LOAD CELL



DESCRIPTION:

The CSP-M is a multi-column, low profile, stainless steel compression load cell. The unique four column design offers excellent insensitivity to eccentric loads whilst maintaining accuracy.

This product is, without doubt, one of the most successful compression cells ever produced and is suitable for use in road and rail weighbridges and process weighing applications.

The fully leak-tested welded construction, advanced cable entry and built-in surge protection tubes ensure that this product can be used successfully in harsh environments.

This product meets the stringent Weights and Measures requirements throughout Europe.

FEATURES:

- Low profile, multi column stainless steel construction
- Hermetically sealed, IP66 and IP68
- Certified to OIML R-60, **4000d**
- Multi-interval and multiple range versions available
- Built-in surge protection tubes (GDTs)
- ATEX certified versions are available for use in potentially explosive atmospheres
- Current calibration output (SC version) ensures easy and accurate parallel connection of multiple load cells
- Digital version available (model SCC)
- **CAPACITIES: 10 → 100 t**

CSP-M: SPECIFICATIONS

Standard Capacities (=E _{max})	t	10, 25, 40, 60, 100 ²				
Accuracy Class According to OIML R-60			C2	C3	C3MI7.5 ³	C4
Max. Number of Verification Intervals (n _{ic})			2000	3000	3000	4000
Minimum Verification Interval (V _{min})			E _{max} /10000	E _{max} /12500	E _{max} /12500	E _{max} /12500
Minimum Verification Interval (V _{min}) - Type MR			--	E _{max} /17500	E _{max} /17500	E _{max} /17500
Minimum Dead Load Output Return - DR			--	--	½E _{max} /7500	--
Accuracy According to Type Designation		CC	C2	C3	C3MI7.5	C4
Combined Error	%S	≤ ± 0.0500	≤ ± 0.0230	≤ ± 0.0200	≤ ± 0.0200	≤ ± 0.0170
Non-Repeatability	%S	≤ ± 0.0200	≤ ± 0.0100	≤ ± 0.0100	≤ ± 0.0100	≤ ± 0.0090
Minimum Dead Load Output Return ¹	%S	≤ ± 0.0500	≤ ± 0.0250	≤ ± 0.0167	≤ ± 0.0067	≤ ± 0.0125
Creep Error (30 Minutes) ¹	%S	≤ ± 0.0600	≤ ± 0.0245	≤ ± 0.0245	≤ ± 0.0245	≤ ± 0.0184
Creep Error (20-30 Minutes) ¹	%S	≤ ± 0.0200	≤ ± 0.0053	≤ ± 0.0053	≤ ± 0.0053	≤ ± 0.0039
Temp. Effect on Min. Dead Load Output	%S _{nom} /5 °C	≤ ± 0.0250	≤ ± 0.0070	≤ ± 0.0056	≤ ± 0.0056	≤ ± 0.0056
Temp. Effect on Min. Dead Load Output - Type MR	%S _{nom} /5 °C	--	--	≤ ± 0.0040	≤ ± 0.0040	≤ ± 0.0040
Temp. Effect on Sensitivity	%S/5 °C	≤ ± 0.0250	≤ ± 0.0060	≤ ± 0.0050	≤ ± 0.0050	≤ ± 0.0035
Minimum Dead Load	%E _{max}	0				
Maximum Safe Over Load	%E _{max}	150				
Ultimate Over Load	%E _{max}	400				
Maximum Safe Side Load	%E _{max}	10				
Deflection at E _{max}	mm	0.36 max.				
Excitation Voltage	V	5...20				
Maximum Excitation Voltage	V	25				
Rated Output (=S)	mV/V	2				
Tolerance on Rated Output	mV/V	± 0.02				
Zero Balance	%S	≤ ± 1.0				
Input Resistance	Ω	450 ± 4.5				
Output Resistance	Ω	480 ± 4.8				
Insulation Resistance	MΩ	≥ 5000				
Compensated Temperature Range	°C	-10...+40				
Operating Temperature Range	°C	-40...+80				
Storage Temperature Range	°C	-40...+90				
Element Material (DIN 1.4542 / EN 60.529)		Stainless Steel 1.4542				
Sealing (DIN 40.050)		IP66 and IP68				
SC-Version (Current Calibration)		Standard				
ATEX options for potentially explosive atmospheres		II2G Ex ib T4/T6, II2D or II3D				

- 1 Applies for the temperature range -10 to +40°C
 2 Available only in CC quality
 3 Maximum application range 0.8*E_{max}

"SC-Version" The "Rated Output" and the "Output Resistance" are balanced in such a way, that the output current is calibrated to within 0.05% of a reference value. This allows an easy parallel connection of multiple load cells.

Accuracy classes C2, C3 and C4 are in agreement with the OIML recommendation R-60. **Accuracy class C1 is also available.** Correct mounting of load cells is essential to ensure optimum performance.

Further information is available on request.

REVERE TRANSDUCERS EUROPE B.V.

Ramshoorn 7
 Postbus 6909, 4802 HX Breda
 The Netherlands
 Tel: (+31) 76-5480700
 Fax: (+31) 76-5412854
 E-mail: info@revere.nl
 www.revere.nl

REVERE TRANSDUCERS INC.

14192 Franklin Ave
 Tustin, CA 92780-7016
 U.S.A.
 Tel: 714.731.1234
 Fax: 714.731.2019
 E-mail: info@reveretransducers.com

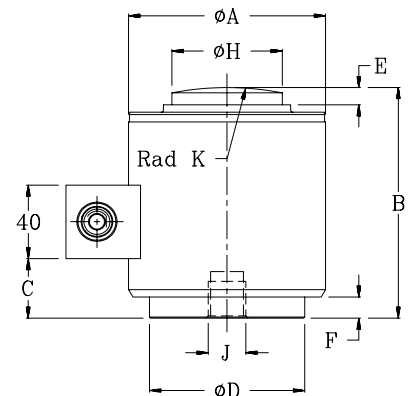
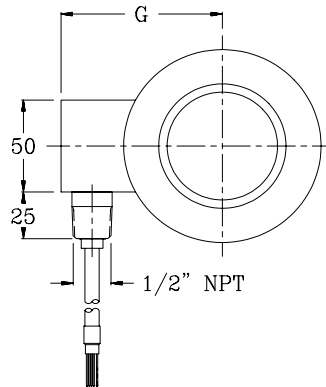

Cable specifications:

Cable length: 20m
 (10 m for 10t version)

Excitation + Green
 Excitation - Black
 Output + White
 Output - Red
 Shield Orange

Cable screen is not connected to load cell body. Performance may be affected if load cell cables are shortened.

Capacity	10,25 t	40,60 t	100 t
A	73.0	105.0	152.4
B	82.5	127.0	184.2
C	12.0	34.0	72.3
D	58.0	82.5	123.8
E	6.5	8.0	23.6
F	1.8	11.0	21.8
G	64.0	87.0	108.2
H	31.8	58.7	79.2
J	M12x1.75 (11 Deep)	M20x2.5 (20 Deep)	
K Rad	152.0	152.0	432.0

Attention:

Dimensions: mm.
 All dimension tolerances according to ISO 2768m, unless otherwise specified

All specifications subject to change without notice
 2/3/62/05 E

REGIONAL OFFICE UK

The Business Centre
 Edward Street, Redditch
 Worcs B97 6HA, UK
 Tel: (+44) 1527-65 888
 Fax: (+44) 1527-64 888
 E-mail: alittlejohn@revere.nl